

Delta bladder expansion tanks are designed to absorb pressure created by expanding fluid in hydronic & cooling systems. When properly installed, the pressure control provided by these tanks will help prevent blowing of relief valves and BTU loss. The removable bladders are suitable for hot water applications and intended for non-potable water.

ASME CODE SEC. VIII DIV. 1
NATIONAL BOARD REGISTERED
CARBON STEEL
PRIMER EXTERIOR
125 PSI DESIGN
STANDARD BLADDER MAX 240°F
(OTHER DESIGN PRESSURES AND
BLADDERS AVAILABLE)
PRE-CHARGED TO 12 PSI

*CUSTOM SIZES AVAILABLE
*OTHER SADDLE SUPPORTS
AVAILABLE

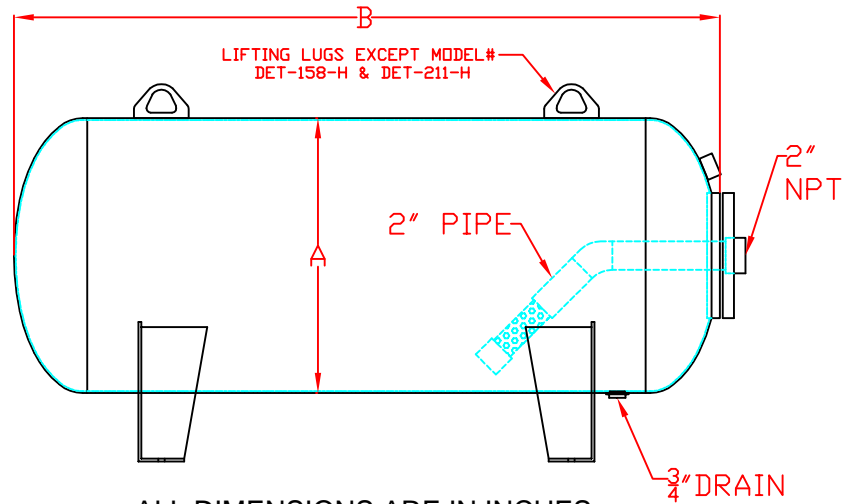
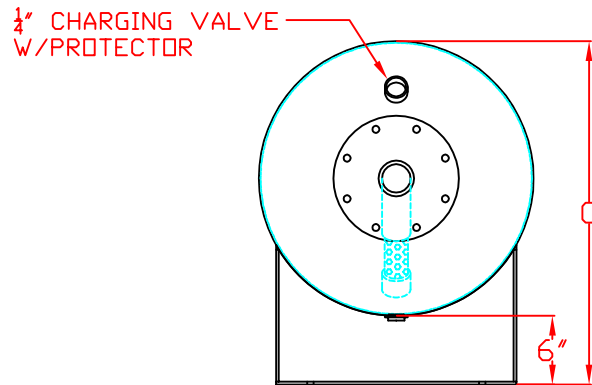

ALL DIMENSIONS ARE IN INCHES

| MODEL | VOLUME (GAL) | A | B | C |
|-----------|--------------|----|---------|----|
| DET-158-H | 158 | 30 | 58 | 36 |
| DET-211-H | 211 | 30 | 76 | 36 |
| DET-264-H | 264 | 36 | 67 | 42 |
| DET-317-H | 317 | 36 | 78 1/2 | 42 |
| DET-370-H | 370 | 36 | 91 | 42 |
| DET-422-H | 422 | 48 | 63 1/2 | 54 |
| DET-528-H | 528 | 48 | 77 1/4 | 54 |
| DET-660-H | 660 | 48 | 94 | 54 |
| DET-793-H | 793 | 48 | 123 1/8 | 54 |

Dimensions are subject to change.
Weights are approximate.