

Delta chill water buffer tanks allow for optimum temperature control in closed-loop systems. These tanks act as water reservoirs to inhibit temperature changes and prevent excessive chiller cycling. The baffle which comes standard in the CWBT increases water mixing and also aids in the separation of air which can be released from the top vent.

ASME CODE SEC. VIII DIV. 1
NATIONAL BOARD REGISTERED
CARBON STEEL
PRIMER EXTERIOR
125 PSI DESIGN
(OTHER DESIGN
PRESSURES AVAILABLE)

*CUSTOM SIZES AVAILABLE

*LEG SUPPORTS AVAILABLE

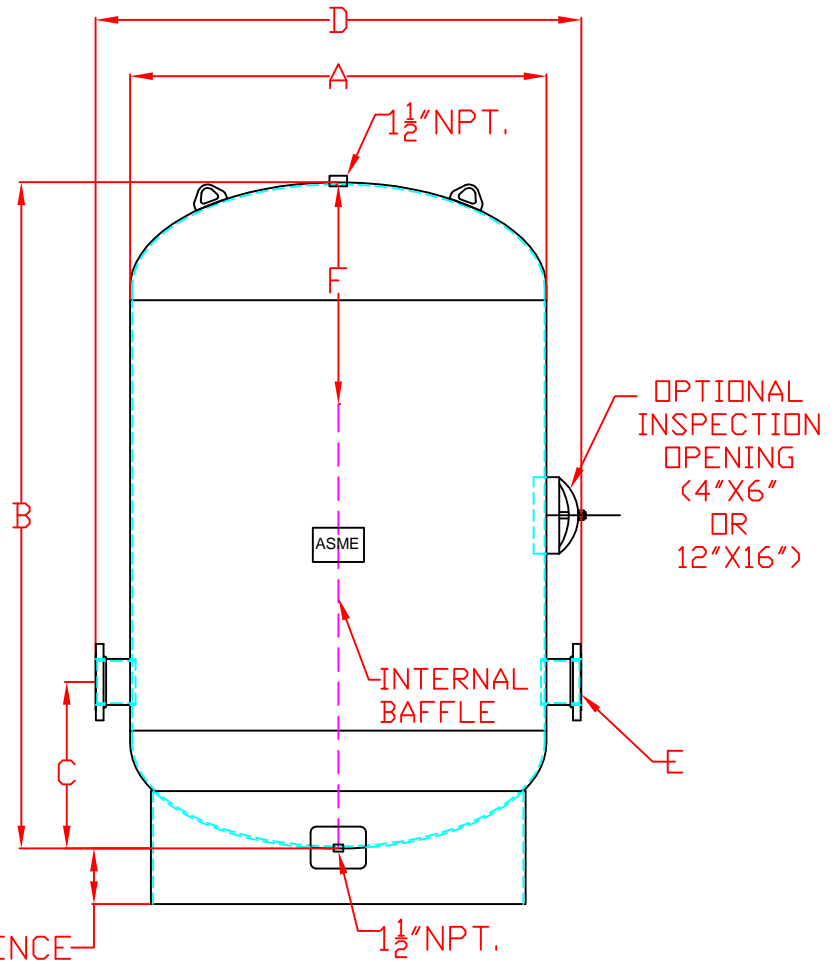

OPENING SIZES E
1" NPT.
1 1/2" NPT
2" NPT/ GROOVED PIPE
2 1/2" NPT/GROOVED PIPE
3" FLANGE/GROOVED PIPE
4" FLANGE/GROOVED PIPE
5" FLANGE/GROOVED PIPE
6" FLANGE/GROOVED PIPE
8" FLANGE/GROOVED PIPE
10" FLANGE/GROOVED PIPE
12" FLANGE/GROOVED PIPE
14" FLANGE/GROOVED PIPE
16" FLANGE/GROOVED PIPE
18" FLANGE/GROOVED PIPE
20" FLANGE/GROOVED PIPE

MODEL	VOLUME (GAL)	A	B	C	D	E	F	WEIGHT (LBS)
DCWTL-120	120	24	60	12	34	SEE	20	160
DCWTL-200	200	30	72	14	40	OPENING	24	250
DCWTL-300	300	36	72	16	46	SIZES	24	375
DCWTL-500	500	42	90	18	52	TABLE	30	400
DCWTL-680	680	48	96	20	58	FOR	32	680
DCWTL-850	850	54	96	22	64	AVAILABLE	32	890
DCWTL-1040	1040	60	96	24	70	SIZES	32	1150

Dimensions are subject to change.
Weights are approximate.