

Delta air purgers are incorporated into hydronic and pumping systems to allow for the removal of entrained air that would otherwise damage or impede function of the system. These are commonly used with a float air vent to allow for air to be automatically vented without requiring repeated manual venting.

ASME CODE SEC. VIII DIV. 1
 NATIONAL BOARD REGISTERED
 CARBON STEEL
 PRIMER EXTERIOR
 150 PSI DESIGN
 (OTHER DESIGN PRESSURES AVAILABLE)

*CUSTOM SIZES AVAILABLE

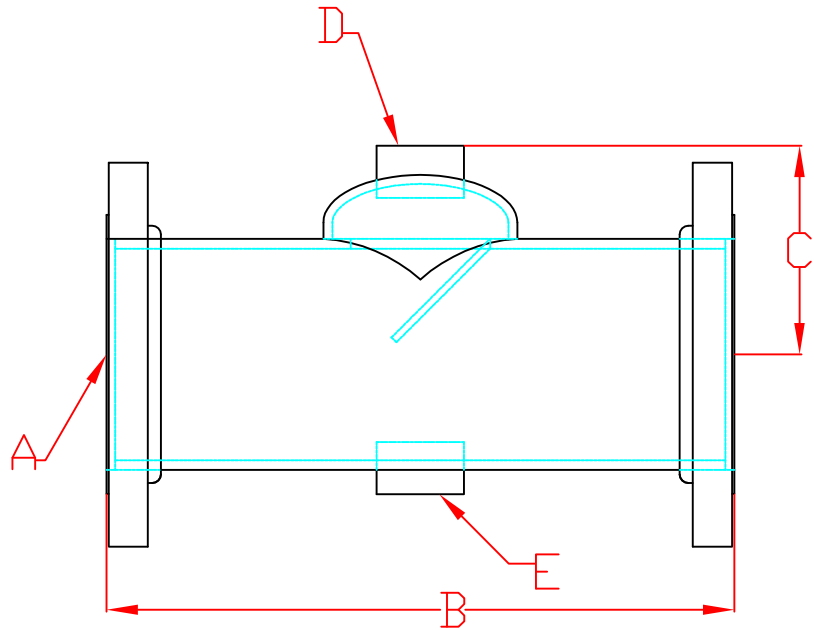

ALL DIMENSIONS ARE IN INCHES

MODEL	A	B	C	D	E
DAP-030	3	3 1/4	12	3/4	3/4
DAP-040	4	4 1/8	12	3/4	3/4
DAP-050	5	5 1/4	15	3/4	3/4
DAP-060	6	6	18	1 1/2	1 1/2
DAP-080	8	7 1/16	24	1 1/2	1 1/2
DAP-100	10	9 5/8	30	1 1/2	1 1/2
DAP-120	12	11 7/16	36	1 1/2	1 1/2

Dimensions are subject to change.
 Weights are approximate.