

Delta air receivers are used for the storage of compressed air. Commonly found in every air compressor, these tanks safely store air in pneumatic systems.

ASME CODE SEC. VIII DIV. 1
NATIONAL BOARD REGISTERED
CARBON STEEL
PRIMER EXTERIOR
150 PSI DESIGN
(OTHER DESIGN
PRESSURES AVAILABLE)

*CUSTOM SIZES AVAILABLE
*OTHER SADDLE SUPPORTS
AVAILABLE

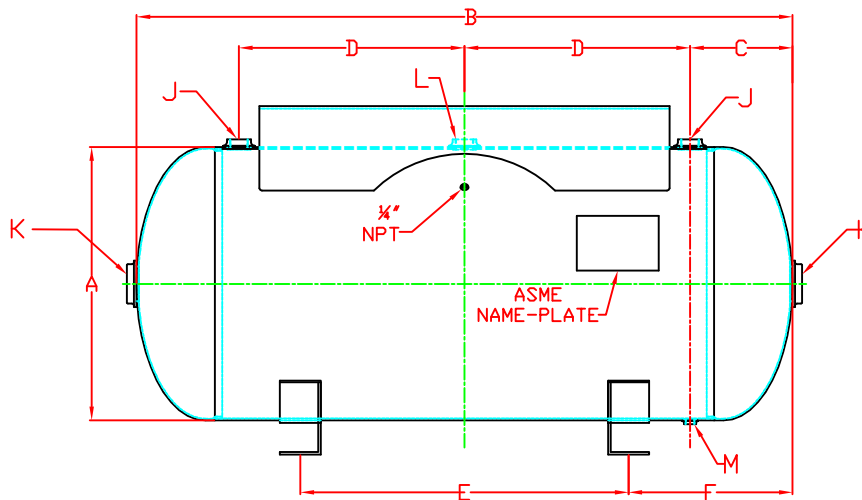
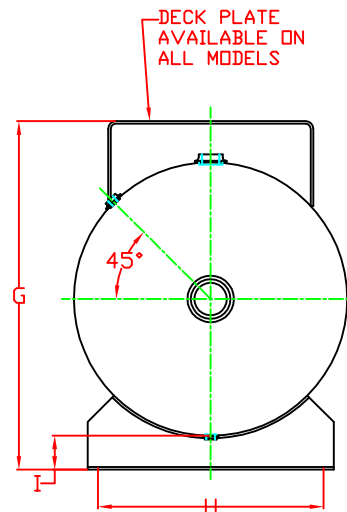

ALL DIMENSIONS ARE IN INCHES

MODEL	VOLUME (GAL)	A	B	C	D	E	F	G	H	I	J	K	L
DAR-015-H	15	12	33	5 1/2	11	20	6 1/2	13	11	1	1/2	3/4	1/4
DAR-020-H	20	14	33	5 7/8	10 5/8	16	8 1/2	16	11 11/16	2	1/2	1 1/2	1/2
DAR-030-H	30	16	38	5 3/4	13 1/4	20	9	18	12 13/16	2	3/4	1 1/2	1/2
DAR-060-H	60	20	48	7 3/4	16 1/4	24	12	22 3/8	16 1/2	2 3/8	3/4	2	1/2
DAR-080-H	80	20	63	9	22 1/2	32	15 1/2	22 3/8	16 1/2	2 3/8	1	2	1/2
DAR-120-H	120	24	67	9 1/2	24	34	16 1/2	26 1/4	20 5/8	2 1/4	1 1/2	2	3/4
DAR-200-H	200	30	72	11 5/8	24 3/8	38	17	33	23 1/2	3	2	2	1
DAR-240-H	240	30	84	11 5/8	30 3/8	44	20	33	23 1/2	3	2	2	1

Dimensions are subject to change.
Weights are approximate.